

A direct acting, two-pipe thermostat is required. Both dampers are normally closed. Hot and cold decks are system pressure independent. Maximum heating and cooling airflow setpoints are constant. When the space temperature is warm, the cold damper is controlling at the maximum CFM setting and the hot damper is closed. As the space temperature drops, the cold damper modulates closed as the hot damper opens. If the space temperature continues to drop, the cold damper shuts off and the hot damper controls at the maximum CFM setting.

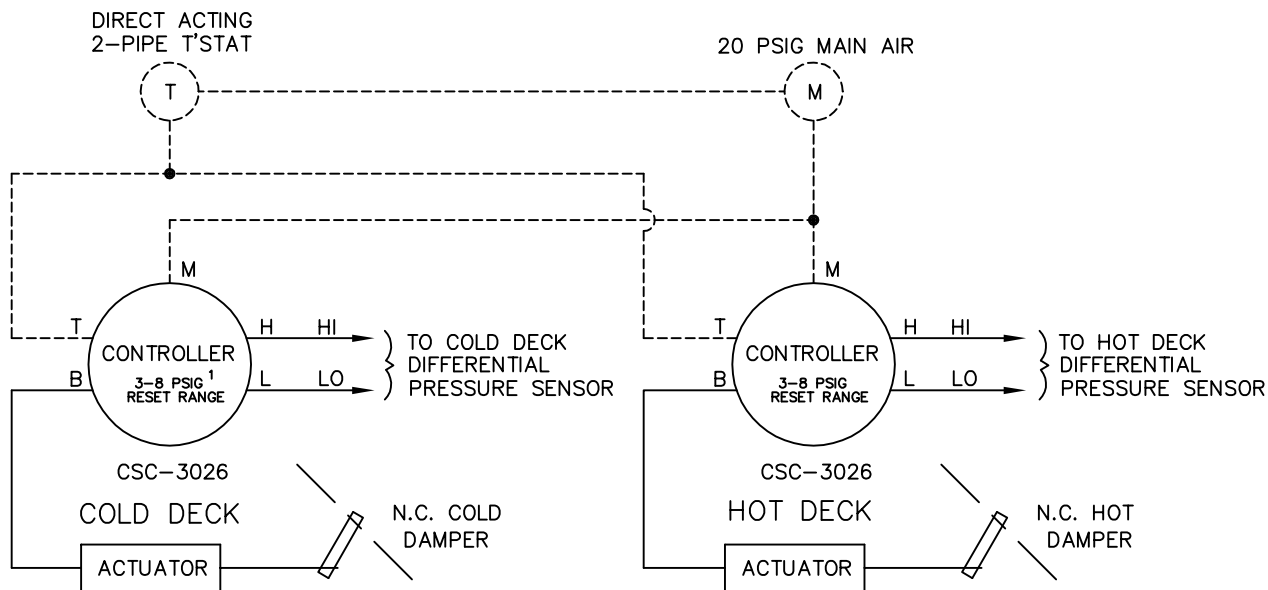
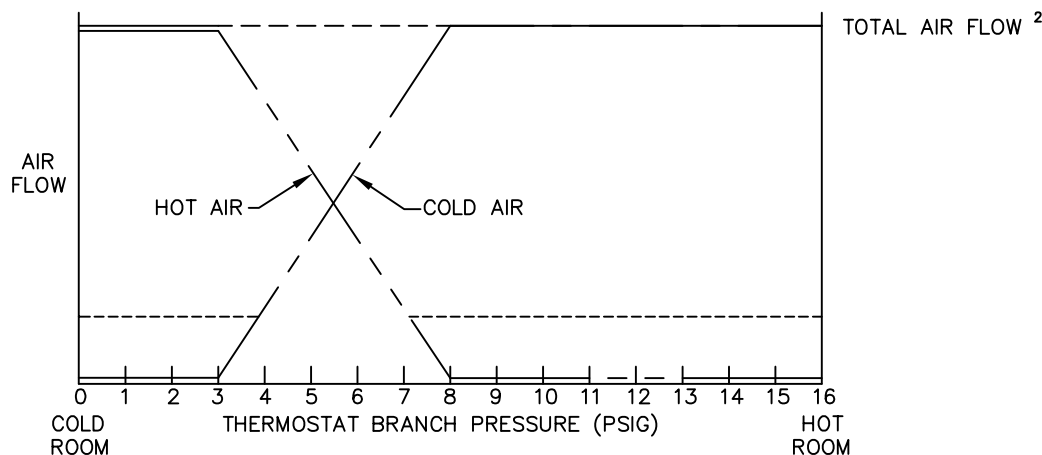

¹ CONTROLLER REQUIRES FIELD CALIBRATION AND SET UP UNLESS OTHERWISE SPECIFIED. IF FACTORY CALIBRATION OPTION IS USED, THE RESET SPAN AND STARTPOINT WILL BE ADJUSTED AS SHOWN ABOVE UNLESS OTHERWISE SPECIFIED.

² AIR VOLUME WILL DEVIATE FROM CONSTANT AIR FLOW DURING THE MIXING STAGE.

———— FACTORY PIPING - - - - - FIELD PIPING

PNEUMATIC AIR CONSUMPTION 2.0 SCFH



TITLE:	DD401RC
	PRESSURE INDEPENDENT PNEUMATIC CONTROLS
THIS DRAWING CONTAINS PROPRIETARY DATA. UNAUTHORIZED DISCLOSURE, REPRODUCTION, OR USE IS STRICTLY PROHIBITED WITHOUT WRITTEN PERMISSION	

DRN BY:	DATE:
WDD	11/06/00
CKD BY:	DATE:
WAE	10/07/08
REV:	06

DRAWING NO.
21134