

SDR Single-Duct VAV Terminals

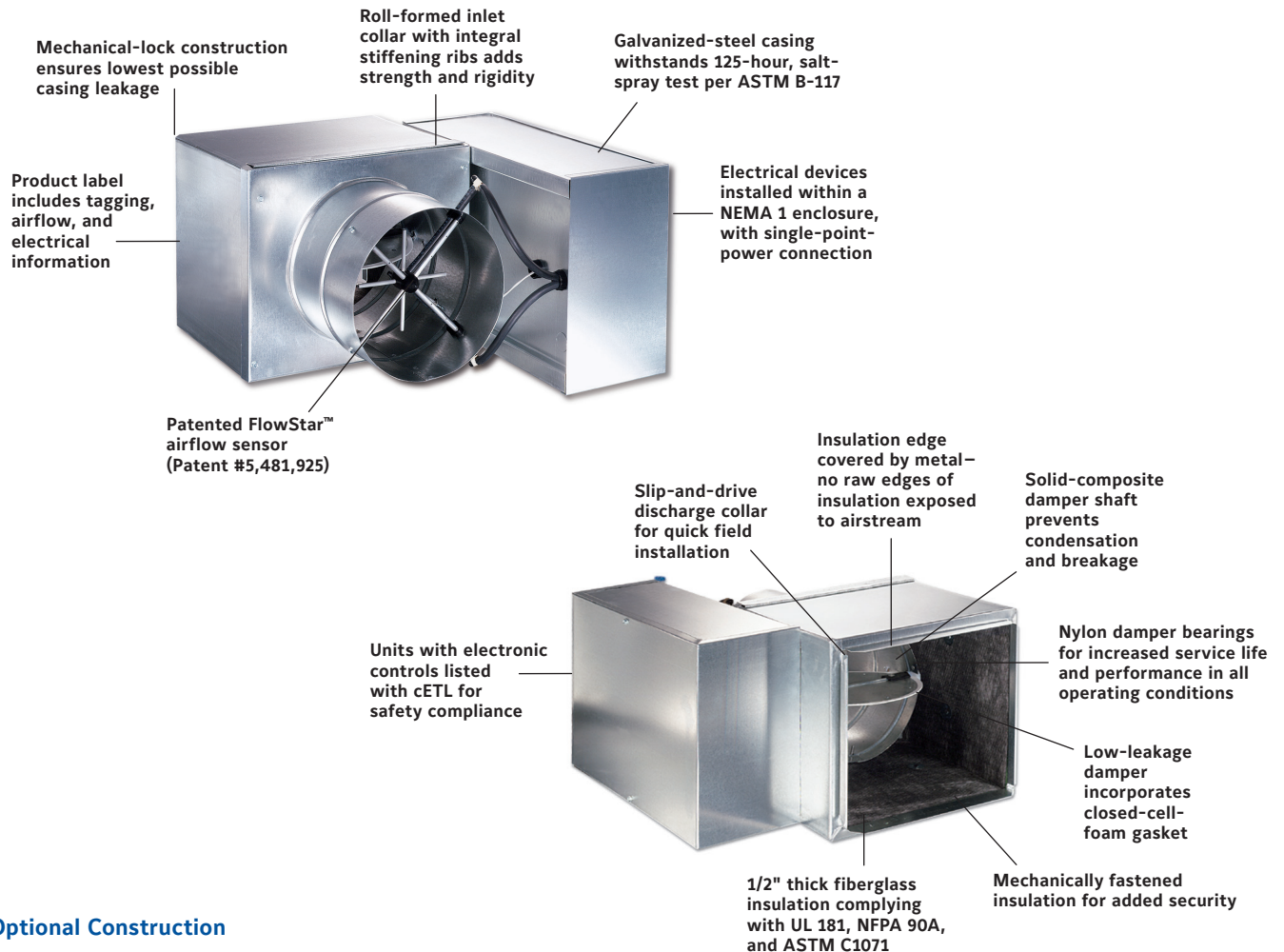

Model SDR construction features

Standard Construction



Optional Construction

Factory-control options:

- Verasys® ZEC Series DDC for BACnet
- Factory mounted consignment DDC
- Pneumatic Controls

For more information, see corresponding Control Selection Guides

Scrim-reinforced, foil-faced insulation meeting ASTM C1136 for mold, mildew and humidity resistance

— or —

1/2" thick elastomeric, closed-cell-foam insulation

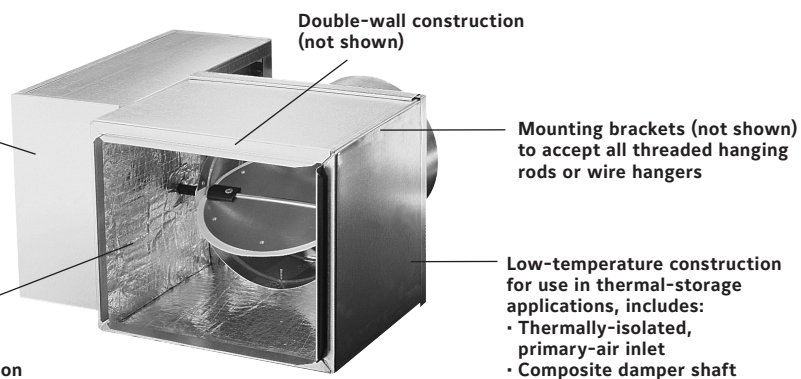

SDR VAV Terminals: Quiet performance with single-duct simplicity

Owners

SDR terminals offer the typical benefits provided by single-duct units, while performing at extremely low sound levels. This is critical in today's buildings where occupants are placing more emphasis on indoor acoustics.

In addition to quiet and accurate temperature control, the building owner will benefit from lower operating costs. The highly amplified, velocity-pressure signal from the FlowStar™ inlet sensor allows precise airflow control at low air velocities. The FlowStar™ sensor's airfoil shape provides minimal pressure drop across the terminal. This allows the central fan to run at a lower pressure and with less brake horsepower, while maintaining occupant comfort.

The SDR terminal is manufactured and assembled with a multi-point, center-averaging, airflow sensor, which provides a signal to the controller enabling it to quietly and precisely measure airflow. Superior flow measuring allows control at lower minimum cubic-feet-per-minute (CFM) values, which reduces energy costs and sound levels.

Designers

SDR terminals provide variable-air-volume (VAV) control beyond the typical single-duct box. The compact cabinet design and quiet operation give the system designer the option to place units directly above occupied spaces. It is not necessary to locate the unit in the crowded space above a hall or corridor. This reduces lengthy and expensive discharge-duct runs.

The SDR terminal provides the ultimate in airflow control with the patented FlowStar™ airflow sensor. No other sensor in the industry can match the FlowStar's ability to quietly and precisely measure airflow. The FlowStar™ sensor ensures accurate control, even when space constraints do not permit long, straight, inlet-duct runs to the terminal.

All metal components are fabricated from galvanized steel. Unlike most manufacturers' terminals, SDR terminals are capable of withstanding a 125-hour, salt-spray test without showing any evidence of red rust.

SDR terminals are available in ten unit sizes to handle airflow capacities between 45 and 8000 CFM.

Contractors

Physical installation is simple with low-profile, compact design and standard metal hanging straps. And control-installation time is minimized with the availability of factory-mounted and calibrated controls. Controls are located on the outside of the unit casing for easy access by maintenance personnel.

A standard, single-point, main-power connection is provided with all electronic controls and electrical components located on the same side of the casing, for quick access, adjustment, and troubleshooting.

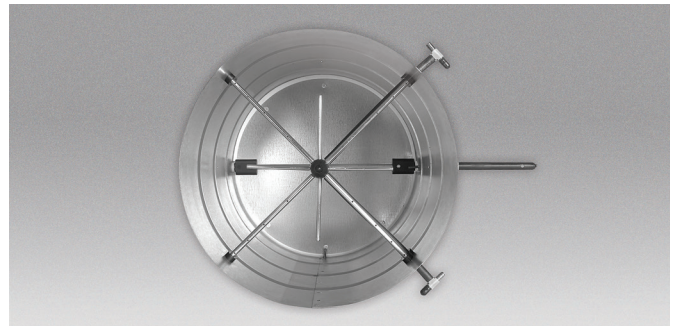

FlowStar™ airflow sensor

The FlowStar™ sensor ensures accurate airflow measurement, regardless of the field-installation conditions. A calibration label and wiring diagram is located on the terminal for quick reference during start-up.

SDR terminals require no periodic maintenance and provide trouble-free operation.

SDR terminals with electronic controls and/or electric heat are listed with ETL as an assembly, and bear the ETL label. SDR terminals and accessories are wired in compliance with all applicable NEC requirements and tested in accordance with AHRI Standard 880.



Model SDR

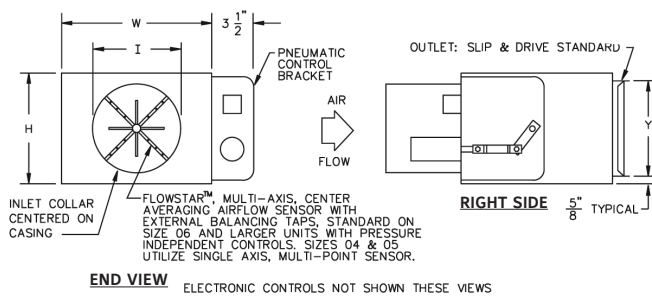
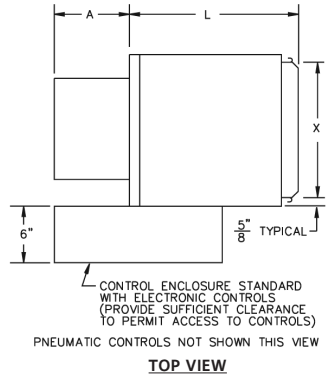

Unit Size	Dimensions						
	W	H	L	A	I	X	Y
4	10" [254]	10" [254]	11" [279]	10-1/2" [267]	3-7/8" [98]	8-3/4" [222]	8-3/4" [222]
5	10" [254]	10" [254]	11" [279]	10-1/2" [267]	4-7/8" [124]	8-3/4" [222]	8-3/4" [222]
6	10" [254]	10" [254]	11" [279]	6-1/2" [165]	5-7/8" [149]	8-3/4" [222]	8-3/4" [222]
8	12" [305]	10" [254]	11" [279]	6-1/2" [165]	7-7/8" [200]	10-3/4" [273]	8-3/4" [222]
10	14" [356]	12-1/2" [318]	13" [330]	6-1/2" [165]	9-7/8" [251]	12-3/4" [324]	11-1/4" [286]
12	16" [406]	15" [381]	13" [330]	6-1/2" [165]	11-7/8" [302]	14-3/4" [375]	13-3/4" [349]
14	20" [508]	17-1/2" [445]	17-1/2" [445]	6-1/2" [165]	13-7/8" [352]	18-3/4" [476]	16-1/4" [413]
16	24" [610]	17-1/2" [445]	17-1/2" [445]	6-1/2" [165]	15-7/8" [403]	22-3/4" [578]	16-1/4" [413]
19	30" [762]	17-1/2" [445]	11" [279]	8" [203]	28-1/4" [718] x 13-7/8" [352]	28-3/4" [730]	16-1/4" [413]
22	34" [864]	17-1/2" [445]	11" [279]	8" [203]	32-1/4" [819] x 15-7/8" [403]	32-3/4" [832]	16-1/4" [413]

Model SDR-WC (Hot-Water Coil)

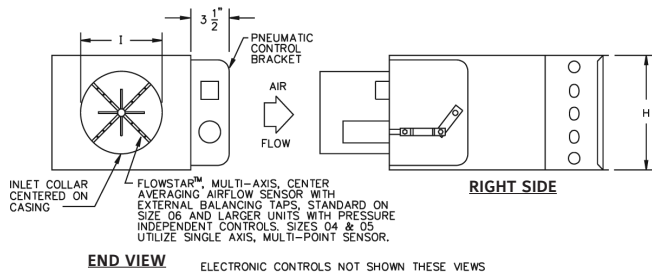
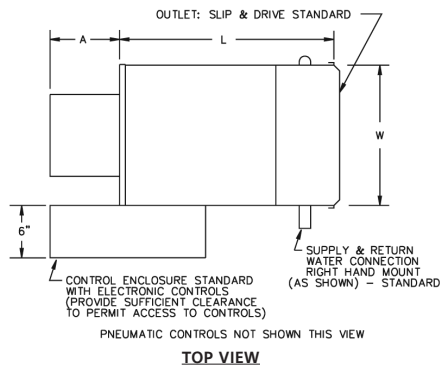

Unit Size	Dimensions				
	W	H	L	A	I
4	10" [254]	10" [254]	15-1/2" [394]	10-1/2" [267]	3-7/8" [98]
5	10" [254]	10" [254]	15-1/2" [394]	10-1/2" [267]	4-7/8" [124]
6	10" [254]	10" [254]	15-1/2" [394]	6-1/2" [165]	5-7/8" [149]
8	12" [305]	10" [254]	15-1/2" [394]	6-1/2" [165]	7-7/8" [200]
10	14" [356]	12-1/2" [318]	17-1/2" [445]	6-1/2" [165]	9-7/8" [251]
12	16" [406]	15" [381]	17-1/2" [445]	6-1/2" [165]	11-7/8" [302]
14	20" [508]	17-1/2" [445]	21-1/2" [546]	6-1/2" [165]	13-7/8" [352]
16	24" [610]	17-1/2" [445]	21-1/2" [546]	6-1/2" [165]	15-7/8" [403]
19	30" [762]	17-1/2" [445]	15-1/2" [394]	8" [203]	28-1/4" [718] x 13-7/8" [352]
22	34" [864]	17-1/2" [445]	15-1/2" [394]	8" [203]	32-1/4" [819] x 15-7/8" [403]

NOTES:

1. All dimensions are in inches [mm] with a tolerance of $\pm 1/8"$ [3mm].
2. Sizes 19 and 22 have rectangular inlet collar.

NOTE: Drawings are not to scale and are not for installation purposes. Refer to www.enviro-tec.com for more information. All data and dimensions are subject to change without notice.

Model SDR-EH (Electric Heat)

DOWNSTREAM P_s MUST BE 0.07 INCHES WATER GAUGE OR GREATER.

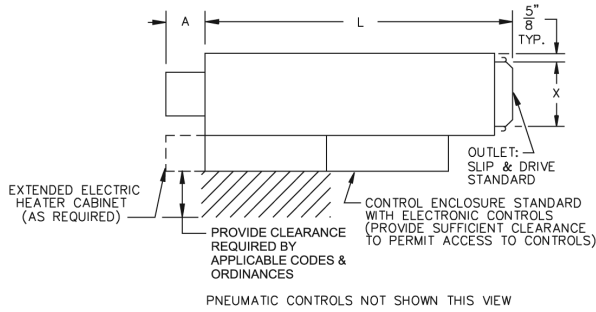

NOTE: SIZES 19 & 22 HAVE RECTANGULAR INLET COLLAR

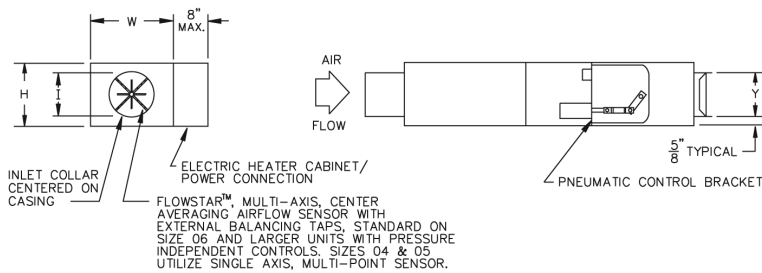

Unit Size	Dimensions						
	W	H	L	I	X	Y	A
4	10" [254]	10" [254]	41" [1041]	3-7/8" [98]	8-3/4" [222]	8-3/4" [222]	10-1/2" [267]
5	10" [254]	10" [254]	41" [1041]	4-7/8" [124]	8-3/4" [222]	8-3/4" [222]	10-1/2" [267]
6	10" [254]	10" [254]	41" [1041]	5-7/8" [149]	8-3/4" [222]	8-3/4" [222]	6-1/2" [165]
8	12" [305]	10" [254]	41" [1041]	7-7/8" [200]	10-3/4" [273]	8-3/4" [222]	6-1/2" [165]
10	14" [356]	12-1/2" [318]	41" [1041]	9-7/8" [251]	12-3/4" [324]	11-1/4" [286]	6-1/2" [165]
12	16" [406]	15" [381]	41" [1041]	11-7/8" [302]	14-3/4" [375]	13-3/4" [349]	6-1/2" [165]
14	20" [508]	17-1/2" [445]	41" [1041]	13-7/8" [352]	18-3/4" [476]	16-1/4" [413]	6-1/2" [165]
16	24" [610]	17-1/2" [445]	41" [1041]	15-7/8" [403]	22-3/4" [578]	16-1/4" [413]	6-1/2" [165]
19	30" [762]	17-1/2" [445]	44-1/2" [1130]	28-1/4" [718] x 13-7/8" [352]	28-3/4" [730]	16-1/4" [413]	1-1/2" [38]
22	34" [864]	17-1/2" [445]	44-1/2" [1130]	32-1/4" [819] x 15-7/8" [403]	32-3/4" [832]	16-1/4" [413]	1-1/2" [38]

Model SDR-SA (Sound Attenuator)

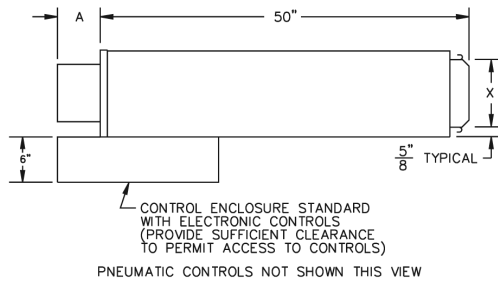

NOTE: SIZES 19 & 22 HAVE RECTANGULAR INLET COLLAR

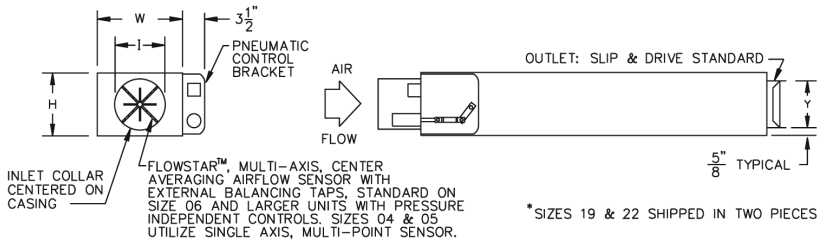

*SIZES 19 & 22 SHIPPED IN TWO PIECES

Unit Size	Dimensions					
	W	H	A	I	X	Y
4	10" [254]	10" [254]	10-1/2" [267]	3-7/8" [98]	8-3/4" [222]	8-3/4" [222]
5	10" [254]	10" [254]	10-1/2" [267]	4-7/8" [124]	8-3/4" [222]	8-3/4" [222]
6	10" [254]	10" [254]	6-1/2" [165]	5-7/8" [149]	8-3/4" [222]	8-3/4" [222]
8	12" [305]	10" [254]	6-1/2" [165]	7-7/8" [200]	10-3/4" [273]	8-3/4" [222]
10	14" [356]	12-1/2" [318]	6-1/2" [165]	9-7/8" [251]	12-3/4" [324]	11-1/4" [286]
12	16" [406]	15" [381]	6-1/2" [165]	11-7/8" [302]	14-3/4" [375]	13-3/4" [349]
14	20" [508]	17-1/2" [445]	6-1/2" [165]	13-7/8" [352]	18-3/4" [476]	16-1/4" [413]
16	24" [610]	17-1/2" [445]	6-1/2" [165]	15-7/8" [403]	22-3/4" [578]	16-1/4" [413]
19*	30" [762]	17-1/2" [445]	8" [203]	28-1/4" [718] x 13-7/8" [352]	28-3/4" [730]	16-1/4" [413]
22*	34" [864]	17-1/2" [445]	8" [203]	32-1/4" [819] x 15-7/8" [403]	32-3/4" [832]	16-1/4" [413]

NOTE: Drawings are not to scale and are not for installation purposes. Refer to www.enviro-tec.com for more information.
All data and dimensions are subject to change without notice.

SDR Terminal Features

STANDARD FEATURES:

Construction

- AHRI Standard 880-certified and labeled
- 22-gauge, galvanized-steel casing and valve
- 1/2" thick, fiberglass insulation, mechanically fastened for added security

Hot-Water Coils

- AHRI Standard 410-certified and labeled
- 1, 2, 3, 4-row coils
- Tested at a minimum of 450 psig under water
- Mechanically expanded copper tubes leak tested to 450 psig air pressure
- Male sweat-type water connections

Primary Air Valve

- Embossed rigidity rings
- Low-thermal-conductance damper shaft with position indicator
- Mechanical stops for open and closed position
- Multi-point, center-averaging, airflow sensor
- Balancing tees
- Plenum-rated sensor tubing

Electrical Components

- cETL listed for safety compliance with UL 1996
- National Electrical Manufacturers Association (NEMA) Type 1 wiring enclosure

Electric Heat

- cETL listed as an assembly for safety compliance
- Integral, electric-heat assembly
- Automatic-reset primary and back-up secondary thermal limits
- Single-point-power connection
- Hinged, electrical-enclosure door
- Fusing per NEC
- Airflow switch
- Ni-chrome elements
- Wiring diagram

OPTIONAL FEATURES:

Construction

- 20-gauge, galvanized-steel construction
- 3/4" or 1" fiberglass insulation
- Scrim-reinforced, foil-faced insulation meeting American Society for Testing and Materials (ASTM) C1136 for mold, mildew, and humidity resistance
- 1/2" elastomeric, closed-cell-foam insulation
- Double-wall construction with 22-gauge liner
- Mounting brackets to accept all threaded hanging rods or wire hangers
- Low-temperature construction for use in thermal-storage applications, including a thermally-isolated, primary-air inlet and a composite damper shaft

Hot-Water Coils

- Low-pressure steam coils
- Multi-circuit coils for reduced water-pressure drop
- Opposite-hand water connections
- Bottom and top access plates for cleaning

Electrical Components

- Toggle-disconnect switch
- Primary and secondary transformer fusing

Electric Heat

- Proportional, solid-state relay (SSR) heater control
- Disconnect (toggle or door-interlocking)
- P.E. switches
- Manual-reset secondary limit

Controls

- Factory-provided controls include:
 - Verasys® ZEC Series DDC for BACnet
 - Pneumatic controls
- Consignment DDC controls (factory-mount and wire controls provided by others)