

VFR Parallel Flow, Fan-Powered, VAV Terminals

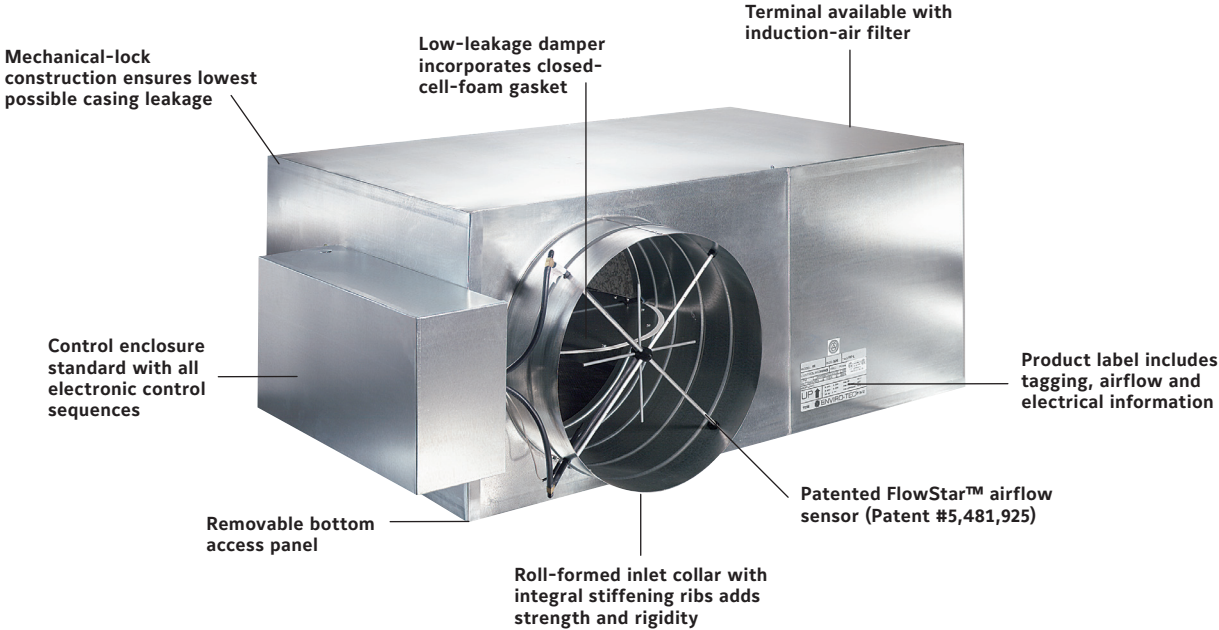

Model VFR construction features

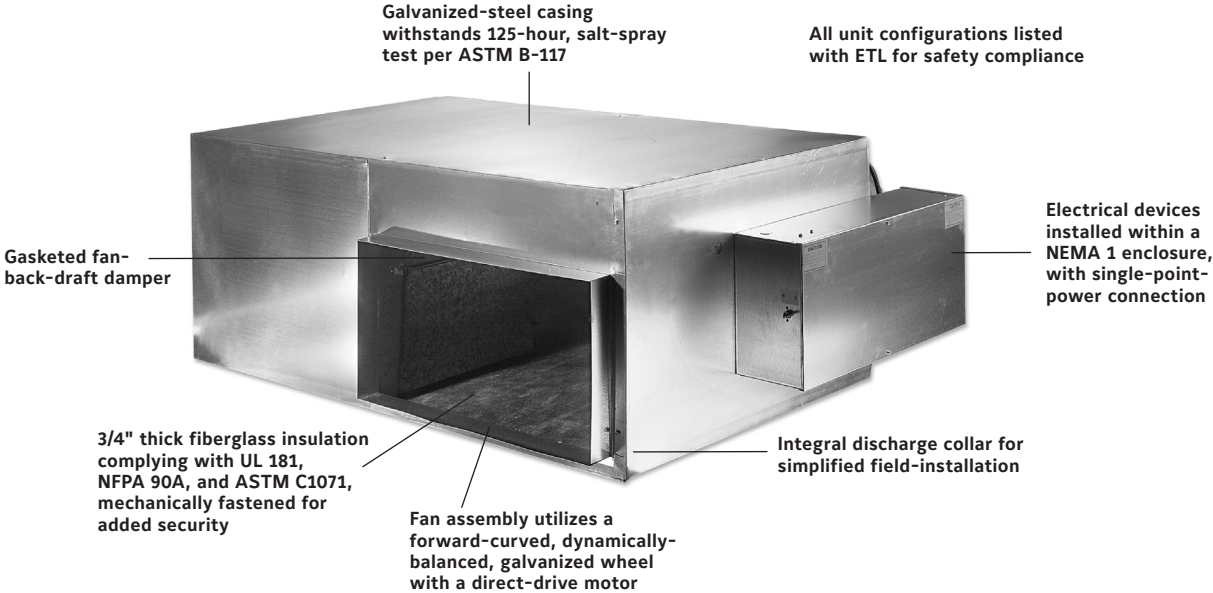

VFR Fan-Powered Terminals: Quiet operation for parallel airflow

Owners

VFR terminals are specifically designed for quiet operation. They also offer improved space comfort and flexibility for a wide variety of heating, ventilating and air-conditioning (HVAC) systems. This is critical in today's buildings where occupants are placing more emphasis on indoor acoustics.

Occupants benefit from a VFR design that minimizes low-frequency (125-250 Hz) sound levels that typically dominate the space sound level.

Superior flow-measuring allows control at lower minimum cubic-feet-per-minute (CFM) values, which reduces energy costs and sound levels while maintaining comfort in the occupied space.

Designers

Due to heightened interest in indoor air quality, many HVAC system designers are focusing on the effects of particulate contamination within a building's occupied space. Often, HVAC system noise is overlooked as a source of occupied-space contamination. The VFR terminal is specifically designed to eliminate obtrusive fan noise from reaching the occupants.

The VFR terminal is manufactured and assembled with a multi-axis, multi-point, center-averaging, airflow sensor. This sensor provides a signal to the controller enabling it to quietly and precisely measure airflow.

Applications for VFR terminals include:

- Parallel, Fan-Powered
- Parallel, Fan-Powered with Reheat

VFR-EH offers electric heat and model VFR-WC offers hot-water heat.

Model VFR terminals are available with Verasys® ZEC Series Direct Digital Control (DDC) for BACnet, consignment DDC, or pneumatic controls. The ZEC Series DDC is specifically designed for use with VFR terminals. Designed by experts in VAV-terminal operation, these controls can accommodate a multitude of control schemes, from the most basic to the most sophisticated sequence of operation.

Contractors

All VFR terminals are thoroughly inspected during each step of the manufacturing process, including a comprehensive pre-shipment inspection, to assure the highest quality product available. Each unit is also run-tested, before leaving the factory, to ensure trouble-free start-up.

The terminals can be installed with metal hanging straps. Hanger brackets, for use with all-thread support rods, or wire hangers are also available.

A single-point, power connection, and factory-calibrated controls, minimize installation time. Electronic controls and electrical components are located on the same side of the casing for quick access, adjustment, and trouble-shooting. Finite fan-speed adjustment is accomplished with an electronic SCR controller.

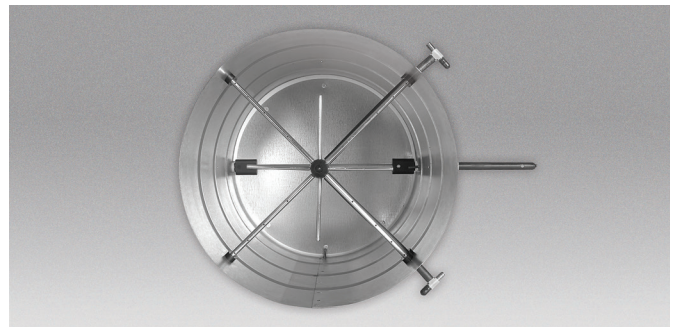

FlowStar™ airflow sensor

VFR terminals utilize three-tap motors that accommodate a broad range of flow and static-pressure conditions. The FlowStar™ sensor ensures accurate airflow measurement, regardless of the installation conditions. A calibration label and wiring diagram is located on the terminal for quick reference during start-up.

VFR terminals require no periodic maintenance other than optional filter replacement. If component replacement becomes necessary, the unit is designed to minimize field labor. The bottom casing panel can be removed to provide easy access to the fan assembly, and the motor electrical leads are easily unplugged. Fan access is also provided through the induction air inlet, except for hot-water coil units.

Complies with National Electric Code (NEC) wiring requirements and meets Air-Conditioning and Refrigeration Institute (AHRI) Standard 880.



Model VFR

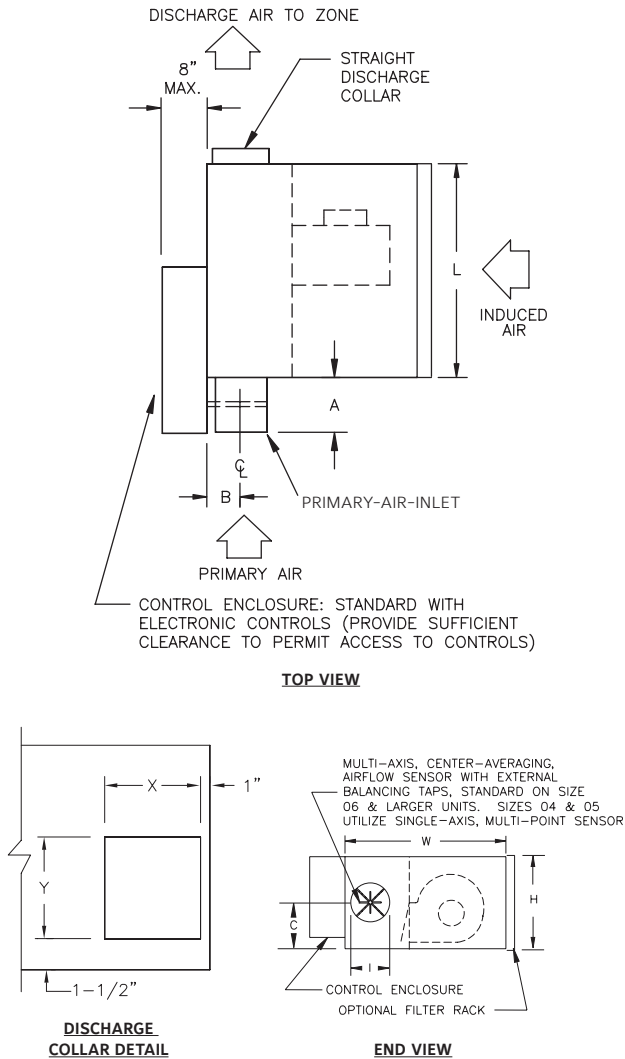

Unit Size	A	B	C	I	X	Y	W	H	L
0404	10-1/2" [254]	5" [127]	7" [178]	3-7/8" [98]	8" [203]	7" [178]			
0504	10-1/2" [254]	5" [127]	7" [178]	4-7/8" [124]	8" [203]	7" [178]			
0604	6-1/2" [165]	5" [127]	7" [178]	5-7/8" [149]	8" [203]	7" [178]	29" [737]	14" [356]	23-1/2" [597]
0606									
0804									
0806	6-1/2" [165]	6" [152]	7" [178]	7-7/8" [200]	11" [279]	7" [178]			
0811									
1006									
1011	6-1/2" [165]	7" [178]	8-1/2" [216]	9-7/8" [251]	14" [356]	10" [254]	37" [940]	17" [432]	
1018									
1211									
1218	6-1/2" [165]	8" [203]	8-1/2" [216]	11-7/8" [302]	16" [406]	10" [254]			
1221									
1411									
1418	6-1/2" [165]	9" [229]	9-1/2" [241]	13-7/8" [352]	22" [559]	12" [305]	45" [1143]		29-1/2" [749]
1421									
1424	6-1/2" [165]	9" [229]	9-1/2" [241]	13-7/8" [352]	22" [559]	12" [305]	49" [1245]	19" [483]	
1621	6-1/2" [165]	10" [254]	9-1/2" [241]	15-7/8" [403]	24" [610]	12" [305]	45" [1143]		
1624	6-1/2" [165]	10" [254]	9-1/2" [241]	15-7/8" [403]	24" [610]	12" [305]	49" [1245]		

Model VFR-WC (Hot-Water Coil)

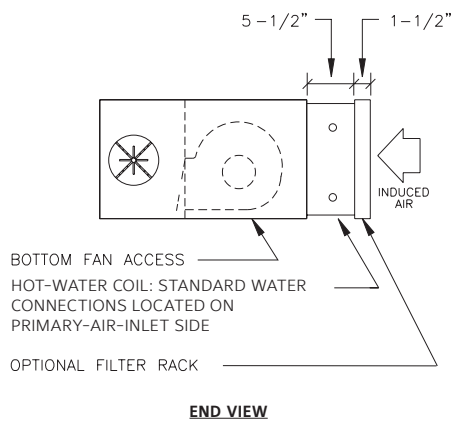

NOTE: Drawings are not to scale and are not for installation purposes. Refer to www.enviro-tec.com for more information. All data and dimensions are subject to change without notice.

Model VFR-EH (Electric Heat)

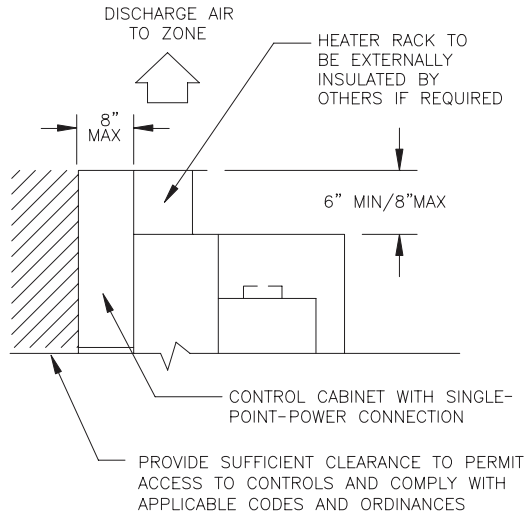

ELECTRIC HEATER DETAIL
(TOP VIEW)

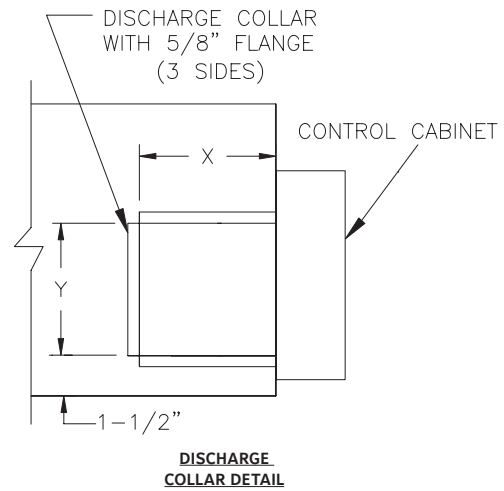

Model VFR Arrangements

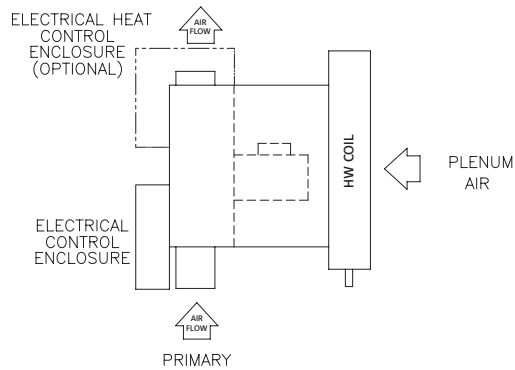

ARRANGEMENT 1
(Left-Hand Control Unit with Left-Hand Coil)

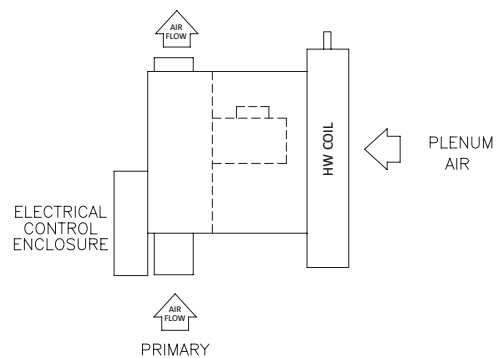

ARRANGEMENT 2
(Left-Hand Control Unit with Right-Hand Coil)

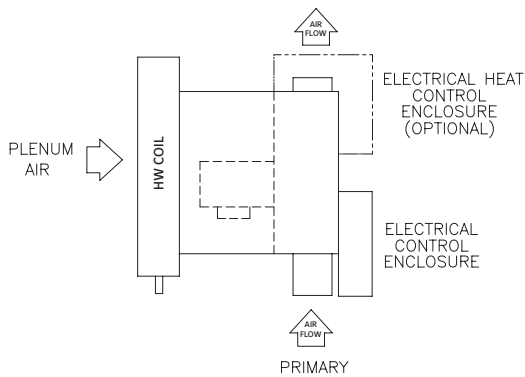

ARRANGEMENT 3
(Right-Hand Control Unit with Right-Hand Coil)

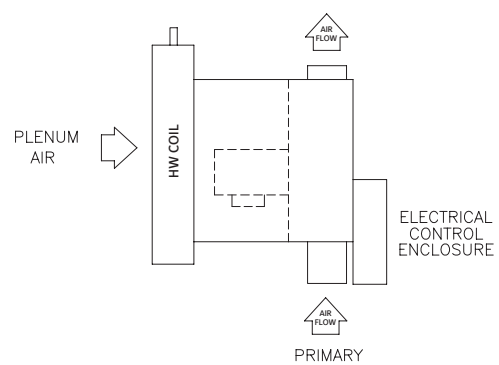

ARRANGEMENT 4
(Right-Hand Control Unit with Left-Hand Coil)

VFR Terminal Features

STANDARD FEATURES:

Construction

- AHRI Standard 880-certified and labeled
- 22-gauge, galvanized-steel casing and valve
- 3/4" thick, fiberglass insulation, mechanically fastened for added security

Hot-Water Coils

- AHRI Standard 410-certified and labeled
- 1, 2, 3, 4-row coils
- Tested at a minimum of 450 psig under water

Fan Assemblies

- Forward-curved, dynamically-balanced, direct-drive, galvanized blower wheel
- 115 to 277-volt, single-phase, three-tap, permanent-split-capacitor (PSC) motor
- SCR fan-speed controller
- Quick-select, motor-speed terminal
- Permanently lubricated motor bearings
- Thermally protected motor
- Vibration-isolation motor mounts
- Single-point wiring

Primary Air Valve

- Embossed rigidity rings
- Low-thermal-conductance damper shaft with position indicator
- Mechanical stops for open and closed position
- Multi-point, center-averaging, airflow sensor
- Balancing tees
- Plenum-rated sensor tubing

Electrical Components

- cETL listed for safety compliance
- NEMA Type 1 wiring enclosure

Electric Heat

- ETL-listed as an assembly for safety compliance
- Integral, electric-heat assembly
- Automatic-reset primary and back-up secondary thermal limits
- Single-point-power connection
- Hinged, electrical-enclosure door
- Fusing per NEC

OPTIONAL FEATURES:

Construction

- 20-gauge, galvanized-steel construction
- 1" insulation
- Scrim-reinforced, foil-faced insulation meeting American Society for Testing and Materials (ASTM) C1136 for mold, mildew, and humidity resistance
- Double-wall construction with 22-gauge liner
- Mounting brackets to accept all threaded hanging rods or wire hangers
- Low-velocity, low-pressure-drop, filter rack and filters located at induction inlet
- Hot-water, steam, or electric heating coils

Fan Assemblies

- 208, 230, 240 and 480-volt, single-phase, PSC motors
- 220/240-volt, 50 Hz motors

Electrical Components

- Full-unit, toggle disconnect and inline motor fusing
- Primary and secondary transformer fusing

Electric Heat

- Proportional, solid-state-relay (SSR), heater control
- Magnetic contactors
- Door-interlocking disconnect switches

Controls

- Factory-provided controls include:
 - Verasys® ZEC Series DDC for BACnet
 - Pneumatic controls
- Consignment DDC controls (factory-mount and wire controls provided by others)