

# CFR Series Fan-Powered, VAV Terminals



# Model CFR construction features

Integral discharge collar  
simplifies field installation



Electrical devices  
installed within a  
NEMA 1 enclosure,  
with single point  
power connection

Fan assembly utilizes a forward curved,  
dynamically balanced, galvanized wheel  
with a direct drive motor

Mechanical lock construction  
ensures lowest possible  
casing leakage

All unit configurations  
listed with ETL for  
safety compliance

Galvanized steel casing withstands 125 hour  
salt spray test per ASTM B-117

Product label includes  
tagging, airflow, and  
electrical information

Mechanically fastened  
insulation for added  
security

Full bottom removable  
access panels

3/4" thick fiberglass  
insulation complying  
with UL 181, NFPA 90A,  
and ASTM C1071

Low leakage damper incorporates closed  
cell foam gasket

Roll formed inlet collar with integral  
stiffening ribs adds strength and rigidity

Patented FlowStar™ airflow sensor  
(Patent #5,481,925)



# CFR Fan-Powered, VAV Terminals: Quiet operation, constant airflow

## Owners

CFR terminals are specifically designed for quiet operation. They also offer improved space comfort and flexibility for a wide variety of heating, ventilating and air-conditioning (HVAC) systems. This is critical in today's buildings where occupants are placing more emphasis on indoor acoustics.

Occupants benefit from a CFR design that minimizes low-frequency (125-250 Hz) sound levels that typically dominate the space sound level.

Superior flow-measuring allows control at lower minimum cubic-feet-per-minute (CFM) values, which reduces energy costs and sound levels while maintaining comfort in the occupied space.

## Designers

Due to heightened interest in indoor air quality, many HVAC system designers are focusing on the effects of particulate contamination within a building's occupied space. Often, HVAC system noise is overlooked as a source of occupied-space contamination. The CFR terminal is specifically designed to eliminate obtrusive fan noise from reaching the occupants, while providing constant air motion in the space.

The CFR terminal is manufactured and assembled with a multi-axis, multi-point, center-averaging, airflow sensor. This sensor provides a signal to the controller enabling it to quietly and precisely measure airflow.

CFR terminals can be used in these types of applications:

- Series Fan, Cooling Only
- Series Fan with Reheat

Model CFR-EH offers electric heat and model CFR-WC offers hot-water heat. Both are available with Electronically Commutated Motor (ECM).

Model CFR terminals are available with Verasys® ZEC Series Direct Digital Control (DDC) for BACnet, pneumatic controls, or consignment controls. Verasys® ZEC DDC is specifically designed for use with CFR terminals. Designed by experts in VAV-terminal operation, these controls can accommodate a multitude of control schemes, from the most basic to the most sophisticated sequence of operation.

## Contractors

All CFR terminals are thoroughly inspected during each step of the manufacturing process, including a comprehensive pre-shipment inspection, to assure the highest quality product available. Each unit is also run-tested, before leaving the factory, to ensure trouble-free start-up.

The terminals can be installed with metal hanging straps. Hanger brackets, for use with all-thread support rods, or wire hangers are also available.

A single-point, power connection, and factory-calibrated controls, minimize installation time. Electronic controls and electrical components are located on the same side of the casing for quick access, adjustment, and troubleshooting. Finite fan-speed adjustment is accomplished with an electronic SCR controller.

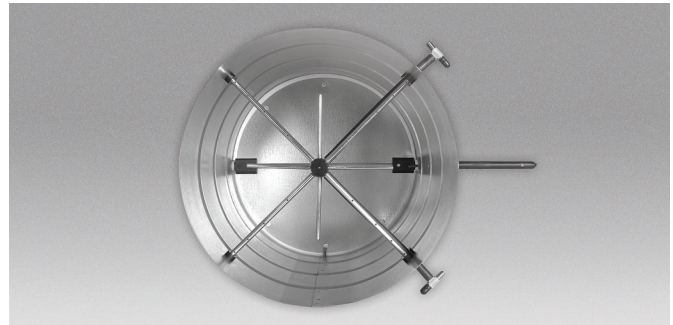

FlowStar™ airflow sensor

CFR terminals utilize three-tap motors that accommodate a broad range of flow and static-pressure conditions. The FlowStar™ sensor ensures accurate airflow measurement, regardless of the installation conditions. A calibration label and wiring diagram is located on the terminal for quick reference during start-up.



CFR terminals require no periodic maintenance other than optional filter replacement. If component replacement becomes necessary, the unit is designed to minimize field labor. The bottom casing panels can be removed to provide easy access to the fan assembly, and the motor electrical leads are easily unplugged.

# Model CFR

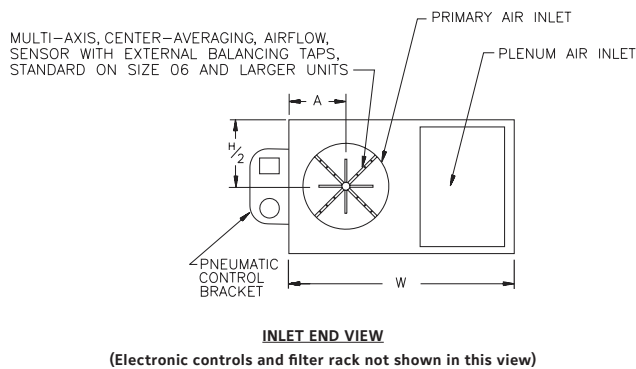
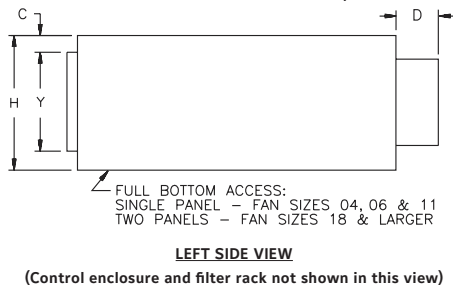
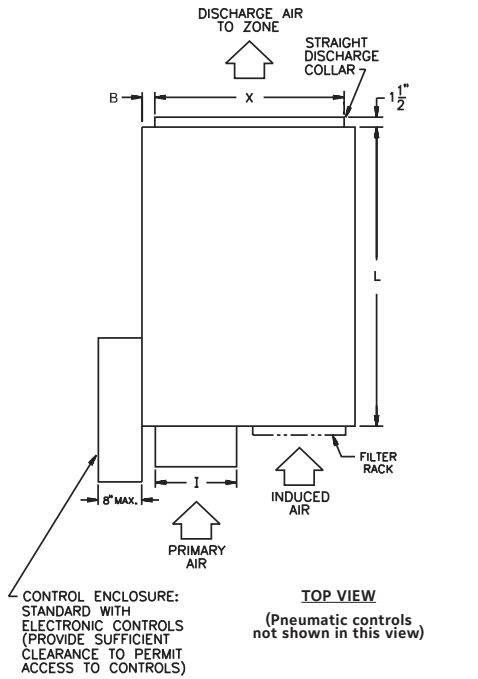

Unit Size	Dimensions									
	I	A	B	C	D	X	Y	W	H	L
0404	3-7/8" [98]	6" [152]	5" [127]	3/4" [19]	10-1/2" [267]	8-3/8" [213]	8" [203]	18" [457]	12" [305]	28" [711]
0504	4-7/8" [124]	6" [152]	5" [127]	3/4" [19]	10-1/2" [267]	8-3/8" [213]	8" [203]	18" [457]	12" [305]	28" [711]
0604	5-7/8" [149]	6" [152]	5" [127]	3/4" [19]	6-1/2" [165]	8-3/8" [213]	8" [203]	18" [457]	12" [305]	28" [711]
0506	4-7/8" [124]	6" [152]	2-1/4" [57]	3/4" [19]	10-1/2" [267]	11" [279]	11" [279]	23-3/8" [594]	14" [356]	35" [889]
0606	5-7/8" [149]	6" [152]	2-1/4" [57]	3/4" [19]	6-1/2" [165]	11" [279]	11" [279]	23-3/8" [594]	14" [356]	35" [889]
0806	7-7/8" [251]	6" [152]	2-1/4" [57]	3/4" [19]	6-1/2" [165]	11" [279]	11" [279]	23-3/8" [594]	14" [356]	35" [889]
0611	5-7/8" [149]	6" [152]	2-1/4" [57]	3/4" [19]	6-1/2" [165]	11" [279]	11" [279]	23-3/8" [594]	14" [356]	35" [889]
0811	7-7/8" [200]	6" [152]	2-1/4" [57]	3/4" [19]	6-1/2" [165]	11" [279]	11" [279]	23-3/8" [594]	14" [356]	35" [889]
1011	9-7/8" [251]	7" [178]	2-1/4" [57]	3/4" [19]	6-1/2" [165]	11" [279]	11" [279]	23-3/8" [594]	14" [356]	35" [889]
0818	7-7/8" [200]	8" [203]	2-1/4" [57]	3/4" [19]	6-1/2" [165]	15" [381]	13-1/2" [343]	29-3/8" [746]	17" [432]	40" [1016]
1018	9-7/8" [251]	8" [203]	2-1/4" [57]	3/4" [19]	6-1/2" [165]	15" [381]	13-1/2" [343]	29-3/8" [746]	17" [432]	40" [1016]
1218	11-7/8" [302]	8" [203]	2-1/4" [57]	3/4" [19]	6-1/2" [165]	15" [381]	13-1/2" [343]	29-3/8" [746]	17" [432]	40" [1016]
1021	9-7/8" [251]	8" [203]	2-1/4" [57]	3/4" [19]	6-1/2" [165]	15" [381]	13-1/2" [343]	29-3/8" [746]	17" [432]	40" [1016]
1221	11-7/8" [302]	8" [203]	2-1/4" [57]	3/4" [19]	6-1/2" [165]	15" [381]	13-1/2" [343]	29-3/8" [746]	17" [432]	40" [1016]
1421	13-7/8" [352]	9" [229]	2-1/4" [57]	3/4" [19]	6-1/2" [165]	15" [381]	13-1/2" [343]	29-3/8" [746]	17" [432]	40" [1016]
1224	11-7/8" [302]	10" [254]	2-1/4" [57]	3/4" [19]	6-1/2" [165]	28" [711]	15" [381]	38" [965]	19" [483]	54" [1372]
1424	13-7/8" [352]	10" [254]	2-1/4" [57]	3/4" [19]	6-1/2" [165]	28" [711]	15" [381]	38" [965]	19" [483]	54" [1372]
1230	11-7/8" [302]	10" [254]	9-3/4" [248]	1-1/4" [32]	6-1/2" [165]	40" [1016]	15" [381]	52" [1321]	19" [483]	62" [1575]
1430	13-7/8" [352]	11-1/2" [292]	9-3/4" [248]	1-1/4" [32]	6-1/2" [165]	40" [1016]	15" [381]	52" [1321]	19" [483]	62" [1575]
1630	15-7/8" [352]	11-1/2" [292]	9-3/4" [248]	1-1/4" [32]	6-1/2" [165]	40" [1016]	15" [381]	52" [1321]	19" [483]	62" [1575]
1440	13-7/8" [403]	11-1/2" [292]	9-3/4" [248]	1-1/4" [32]	6-1/2" [165]	40" [1016]	15" [381]	52" [1321]	19" [483]	62" [1575]
1640	15-7/8" [352]	11-1/2" [292]	9-3/4" [248]	1-1/4" [32]	6-1/2" [165]	40" [1016]	15" [381]	52" [1321]	19" [483]	62" [1575]
1644	15-7/8" [352]	11-1/2" [292]	9-3/4" [248]	3-1/4" [83]	6-1/2" [165]	40" [1016]	15" [381]	52" [1321]	19" [483]	62" [1575]
1844	15-7/8" [352] x 15-7/8" [352]	11-1/2" [292]	9-3/4" [248]	3-1/4" [83]	6-1/2" [165]	40" [1016]	15" [381]	52" [1321]	19" [483]	62" [1575]

## NOTES:

1. All dimensions are in inches [mm] with a tolerance of  $\pm 1/8"$  [3mm].

**NOTE:** Drawings are not to scale and are not for installation purposes. Refer to [www.enviro-tec.com](http://www.enviro-tec.com) for more information. All data and dimensions are subject to change without notice.

**Model CFR-WC  
(Hot-Water Coil)**

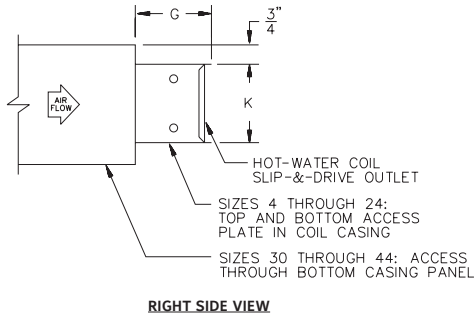

Fan Size	G	J	K	M
04	10" [254]	12" [305]	10" [254]	3" [76]
06, 11	10" [254]	16" [406]	12-1/2" [318]	1/2" [13]
18, 21	10" [254]	22" [559]	12-1/2" [318]	1/2" [13]
24	10" [254]	28" [711]	17-1/2" [445]	1/2" [13]
30, 40	6" [152]	40" [1016]	17-1/2" [445]	9-3/4" [248]
44	6" [152]	44" [1118]	17-1/2" [445]	5-3/4" [146]

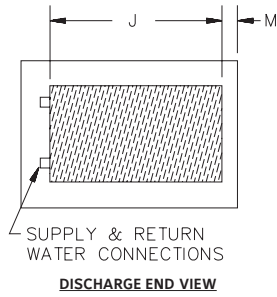

**Model CFR-EH  
(Electric Heat)**

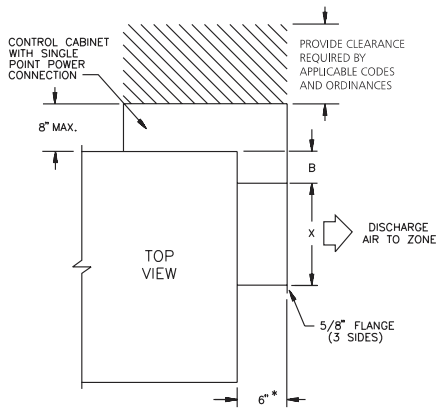

\*HEATER RACK MAY EXTEND UP TO 12" DEPENDING ON OPTIONS

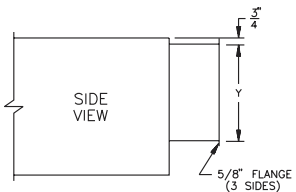

FAN SIZES 04, 06, 11, 18, 21 AND 24

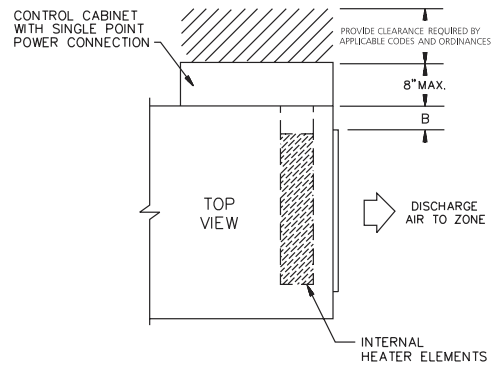

FAN SIZES 30, 40 AND 44

**NOTE:** Drawings are not to scale and are not for installation purposes. Refer to [www.enviro-tec.com](http://www.enviro-tec.com) for more information. All data and dimensions are subject to change without notice.



# CFR Terminal Features

## STANDARD FEATURES:

### Construction

- AHRI Standard 880-certified and labeled
- 22-gauge, galvanized-steel casing and valve
- 3/4" thick, fiberglass insulation, mechanically fastened for added security

### Hot-Water Coils

- 1, 2, 3, 4-row coils
- Tested at a minimum of 450 psig under water

### Fan Assemblies

- Forward-curved, dynamically-balanced, direct-drive, galvanized blower wheel
- 115 to 277-volt, single-phase, three-tap, permanent-split capacitor (PSC) motor
- SCR fan-speed controller
- Quick-select, motor-speed terminal
- Permanently lubricated motor bearings
- Thermally protected motor
- Vibration-isolation motor mounts
- Single-point wiring

### Primary Air Valve

- Embossed rigidity rings
- Low-thermal-conductance damper shaft with position indicator
- Mechanical stops for open and closed position
- Multi-point, center-averaging, airflow sensor
- Balancing tees

### Electrical Components

- cETL listed for safety compliance with UL 1996
- National Electrical Manufacturers Association (NEMA) Type 1 wiring enclosure

### Electric Heat

- cETL listed as an assembly for safety compliance
- Integral, electric-heat assembly
- Automatic-reset primary and back-up secondary thermal limits
- Single-point-power connection
- Hinged, electrical-enclosure door
- Fusing per NEC
- Ni-chrome elements
- Wiring diagram and ETL label
- Fan-interlock device (relay or P.E. switch)

## OPTIONAL FEATURES:

### Construction

- 20-gauge, galvanized-steel construction
- 1" insulation
- Scrim-reinforced, foil-faced insulation meeting American Society for Testing and Materials (ASTM) C1136 for mold, mildew, and humidity resistance
- 1/2" thick elastomeric closed cell foam insulation
- Double-wall construction with 22-gauge liner
- Mounting brackets to accept all threaded hanging rods or wire hangers
- Low-temperature construction for use in thermal-storage applications, including a thermally-isolated, primary air inlet and a composite damper shaft
- Low-velocity, low-pressure-drop, filter rack and filters located at induction inlet and/or radiated sound damper
- Hot-water, steam, or electric heating coils mounted at unit discharge-access plate upstream of hydronic coil (standard)

### Fan Assemblies

- 208, 230, 240 and 480-volt, single-phase, PSC motors
- 220/240-volt, 50 Hz motors
- 120, 208, 240, and 277-volt ECM™ motors

### Electrical Components

- Full-unit, toggle disconnect and inline motor fusing
- Primary and secondary transformer fusing

### Electric Heat

- Proportional, solid-state-relay (SSR) heater control
- Disconnect (toggle or door-interlocking)
- Magnetic contactors
- P.E. switches
- Manual-reset secondary limit
- Airflow switch

### Controls

- Factory-provided controls include:
  - Verasys® ZEC Series DDC for BACnet
  - Pneumatic controls
- Consignment DDC controls (factory-mount and wire controls provided by others)