

Instructions to Replace Fan Coil Relay Board (FCRB) with Fan Relay Board 2 (FRBii)

WARNING

Failure to adhere to the instructions within this document could cause injury, death or damage to equipment.

1. Setup

- a. Remove power to the unit in accordance with Lockout-Tagout (LOTO) procedures.
- b. Tool(s) required
 - i. 1/8" flat bladed screwdriver
 - ii. Wire strippers (capable of stripping 16AWG)
 - iii. 1/4" Nut driver OR 6mm nut driver
 - iv. Pliers (optional, but helpful if needed to remove quick-connects from Y connector)
- c. NOTE: When connecting male quick-connects to female quick-connects, ensure that the male stab fits properly within the female connector. See Figures 1 and 2 below:

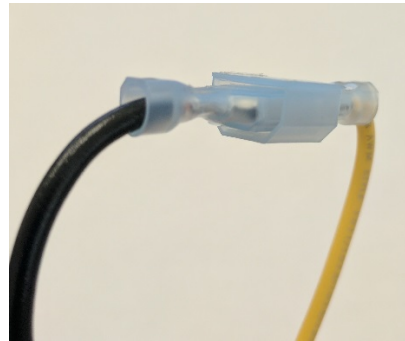
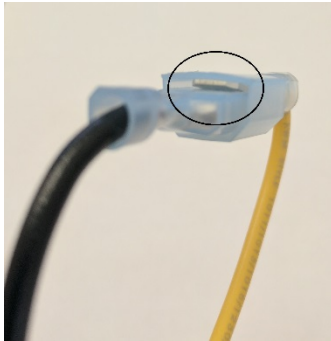

Figure 1 (left): Improper connection (male stab circled; not seated in female connector)

Figure 2 (right): Proper connection (male stab seated within female connector)

- d. The following legend applies for the visual sections of these instructions shown in the figures throughout this document:



REMOVE WIRE FROM BOARD

2. Identify Components

- a. Locate the FCRB within the control enclosure (see Figure 3).

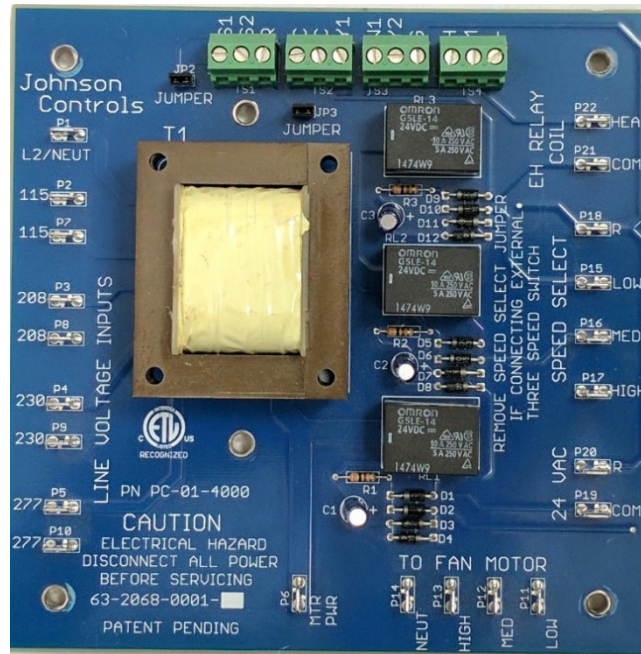
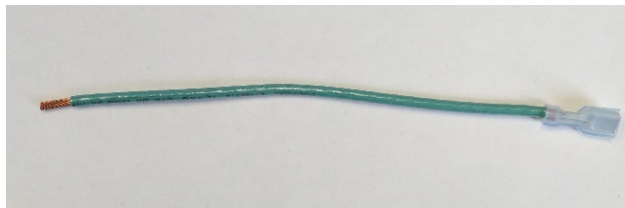

Figure 3 – Fan Control Relay Board (FCRB)

- b. Confirm all parts listed in replacement kit are present. The part number of the retrofit kit will be 66-XXXXX-xx, where the “-xx” is different depending on the unit’s motor type.

PSC Motor (66-XXXXX-01)		
QTY	Reference Designator	Description
1	BD1	FRBii Board Assembly
1	WH1	Wire Harness – 1 female quick-connect and 1 stripped end, green wire
1	WH2	Wire Harness – 18 position male connector and 10 male quick-connects
1	WH3	Wire Harness – 5 position male connector and 2 female quick – connects
1	WH4	Wire Harness – 5 position male connector and 1 female quick – connects
1	WH5	Wire Harness – 4 position male connector and 4 male quick – connects (Dual Motor Units Only) – quantity will be 2 instead of 1
1	WD1	Revised Wiring Diagram
7	-	#8 – 3/4” Hex washer self-tapping screw (6 required + 1 extra)



WH1



WH4 (colors and wire locations will vary depending on unit voltage)

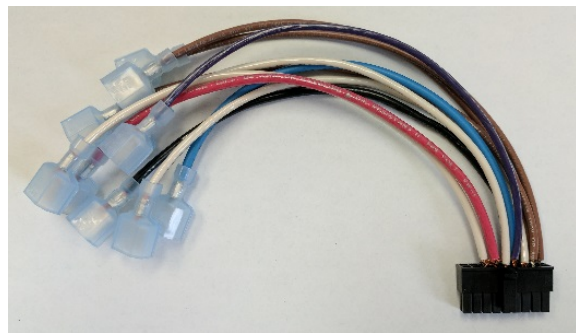

WH2

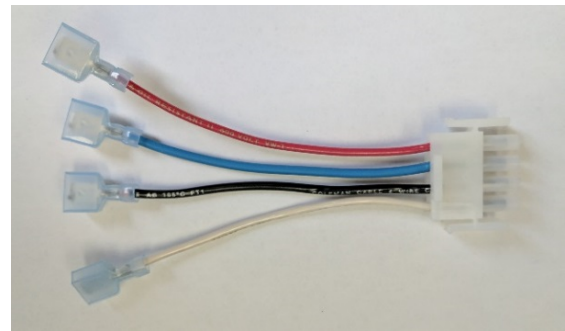

WH5



WH3 (colors and wire locations will vary depending on unit voltage)

EC Motor (66-XXXXX-02)		
QTY	Reference Designator	Description
1	BD1	FRBii Board Assembly
1	WH1	Wire Harness – 1 female quick-connect and 1 stripped end, green wire
1	WH2	Wire Harness – 18 position male connector and 10 male quick-connects
2	WH3	Wire Harness – 5 position male connector and 2 female quick – connects
1	WH5	Wire Harness – 4 position male connector and 4 male quick – connects
1	WD1	Revised Wiring Diagram
7	-	#8 – 3/4” Hex washer self-tapping screw (6 required + 1 extra)
2	-	(Dual Motor Units Only) – Lever nut, 3-position

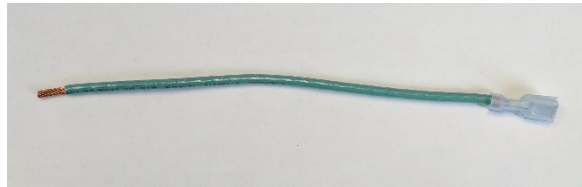

WH1

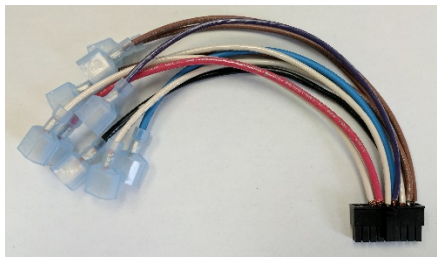

WH2

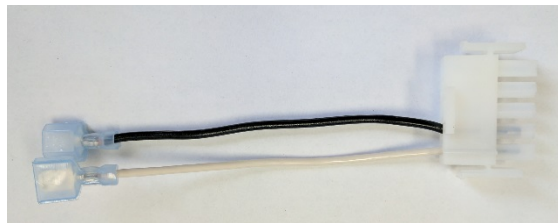

WH3 (colors and wire location will vary depending on unit voltage)

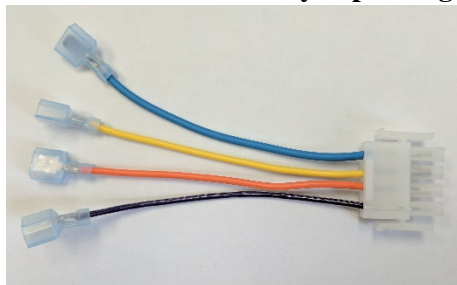

WH5

EC 3-speed Motor (66-XXXXX-03)		
QTY	Reference Designator	Description
1	BD1	FRBii Board Assembly
1	WH1	Wire Harness – 1 female quick-connect and 1 stripped end, green wire
1	WH2	Wire Harness – 18 position male connector and 10 male quick-connects
2	WH3	Wire Harness – 5 position male connector and 2 female quick – connects
1	WH5	Wire Harness – 4 position male connector and 3 male quick – connects
1	WD1	Revised Wiring Diagram
7	-	#8 – 3/4” Hex washer self-tapping screw (6 required + 1 extra)
2	-	(Dual Motor Units Only) – Lever nut, 3-position

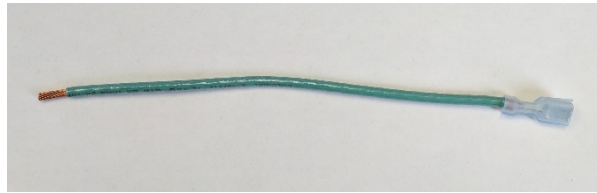

WH1

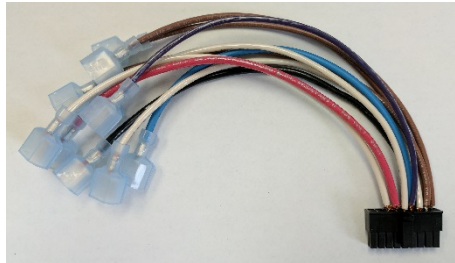

WH2



WH3 (colors and wire location will vary depending on unit voltage)

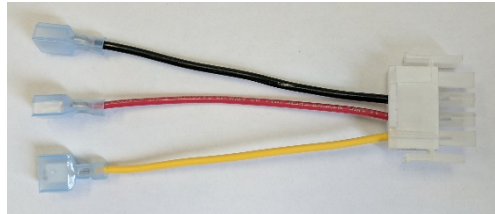

WH5

3. Remove FCRB Power Wires



Wires on primary side of transformer are line voltage.

- a. Remove WHITE/RED wire from P1 (NEUT) on FCRB.
- b. Remove BLACK wire from the appropriate line voltage pin on FCRB. The wire's location will depend on the unit's voltage (see Figure 4):
 - i. 115V – P2
 - ii. 208V – P3
 - iii. 230V – P4
 - iv. 277V – P5
 - v. 220V/50Hz – P4

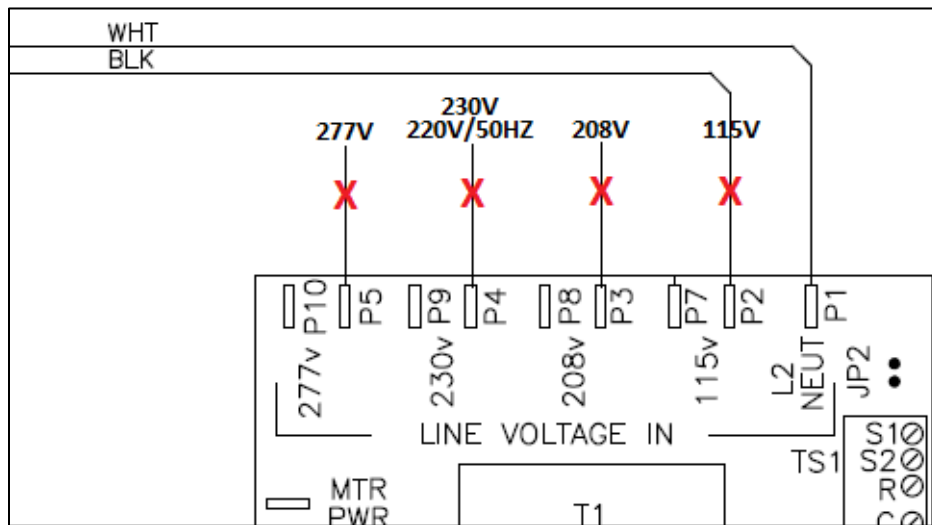

Figure 4 – Removing the FCRB incoming power

4. Remove motor wires (PROCEED TO APPROPRIATE SECTION BELOW BASED ON MOTOR TYPE)

a. PSC motors (see Figure 5)

- i. Remove WHITE wire from NEUT on “TO FAN MTR” portion of FCRB.
- ii. Remove BLACK wire from HIGH on “TO FAN MTR” portion of FCRB.
- iii. Remove BLUE wire from MED on “TO FAN MTR” portion of FCRB.
- iv. Remove RED wire from LOW on “TO FAN MTR” portion of FCRB.

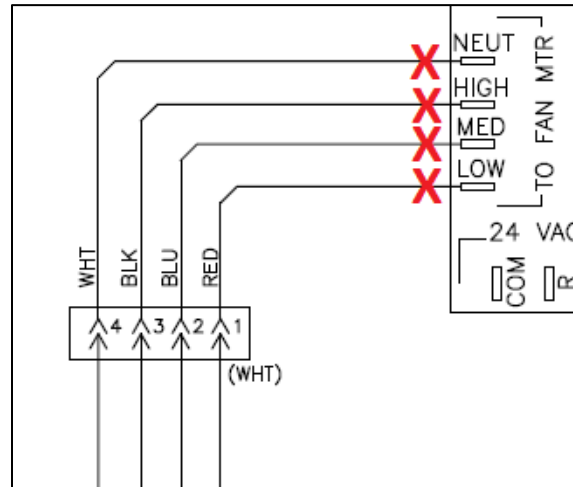

Figure 5 – Removing PSC motor wires

b. EC motors (see Figure 6)

- i. Remove BLUE wire from MTR PWR on FCRB.
- ii. Remove YELLOW wire from HIGH on “TO FAN MTR” portion of FCRB.
- iii. Remove ORANGE wire from MED on “TO FAN MTR” portion of FCRB.
- iv. Remove PURPLE wire from LOW on “TO FAN MTR” portion of FCRB.
- v. Remove BLACK wire from “LINE VOLTAGE IN” portion of FCRB (NOTE: for dual motor units ONLY, there will be two wires connected. Remove butterfly/Y connector and remove both wires from connector). Exact location of wire will be determined by the unit’s voltage (115V shown in Figure 6):
 1. 115V – P7
 2. 208V – P8
 3. 230V – P9
 4. 277V – P10
 5. 220V/50Hz – P9
- vi. Remove WHITE wire from NEUT on “TO FAN MTR” portion of FCRB (NOTE: for dual motor units ONLY, there will be two wires connected. Remove butterfly/Y connector and remove both wires from connector).
- vii. Remove WHITE wire from COM on “24 VAC” portion of FCRB.
- viii. Remove BLACK wire from R on “24 VAC” portion of FCRB.

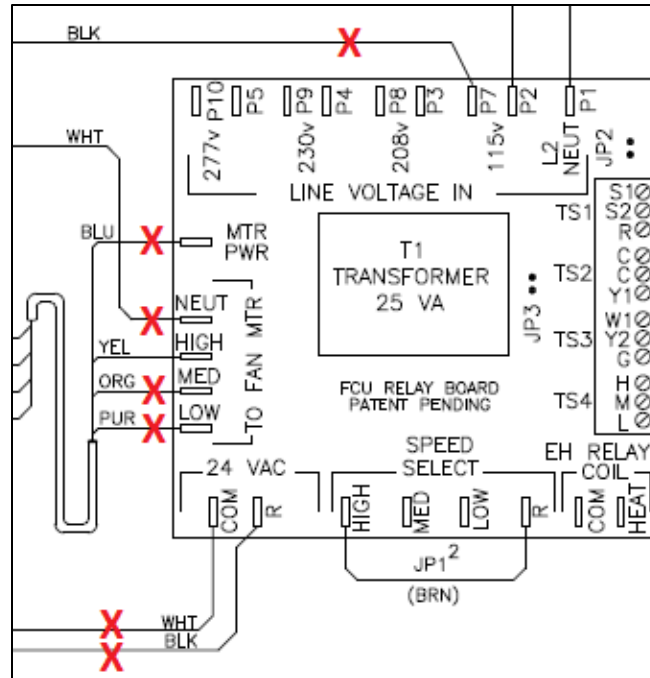

Figure 6 – Removing EC motor wires

c. EC 3SPD Motors (see Figure 7)

- i. Remove BLACK/BLUE wire from HIGH on “TO FAN MTR” portion of FCRB.
- ii. Remove RED/GRAY wire from MED on “TO FAN MTR” portion of FCRB.
- iii. Remove YELLOW/ORANGE wire from LOW on “TO FAN MTR” portion of FCRB.
- iv. Remove WHITE wire from NEUT on “TO FAN MTR” portion of FCRB (NOTE: for dual motor units ONLY, there will be two wires connected. Remove butterfly/Y connector and remove both wires from connector).
- v. Remove BLACK wire from “LINE VOLTAGE IN” portion of FCRB (NOTE: for dual motor units ONLY, there will be two wires connected. Remove butterfly/Y connector and remove both wires from connector). Exact location of wire will be determined by the unit’s voltage (115V shown in Figure 5):
 1. 115V – P7
 2. 208V – P8
 3. 230V – P9
 4. 277V – P10
 5. 220V/50Hz – P9
- vi. Remove PURPLE wire from COM on “24 VAC” portion of FCRB.
- vii. Remove jumper wire connected from “MTR PWR” to R on “24 VAC” portion of FCRB. Retain this jumper for use in Step 9.

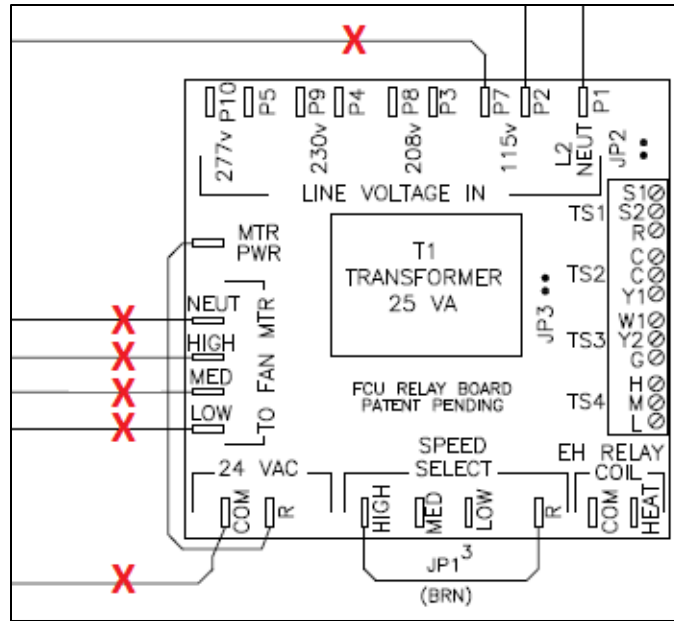

Figure 7 – Removing EC 3 SPD motor wires

5. Remove speed select wires

- a. If unit has no 3-speed switch (see Figure 8):
 - i. Remove BROWN jumper wire from HIGH on “SPEED SELECT” portion of FCRB.
 - ii. Remove other side of BROWN jumper wire from R on “SPEED SELECT” portion of FCRB.
 - iii. Retain jumper wire for use in Step 11.

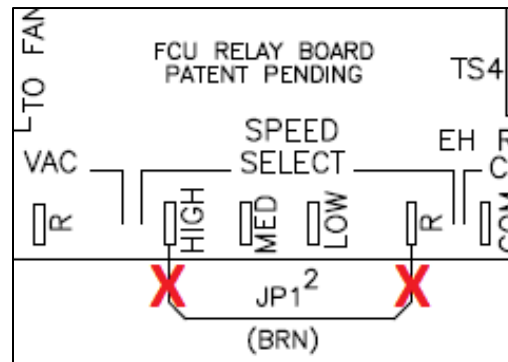

Figure 8 – Removing speed select jumper on unit WITH NO 3-speed switch

- b. If unit has unit mounted 3-speed switch (see Figure 9)
 - i. Remove BLACK wire from HIGH on “SPEED SELECT” portion of FCRB.
 - ii. Remove BLUE wire from MED on “SPEED SELECT” portion of FCRB.
 - iii. Remove RED wire from LOW on “SPEED SELECT” portion of FCRB.
 - iv. Remove BLACK wire from R on “SPEED SELECT” portion of FCRB.

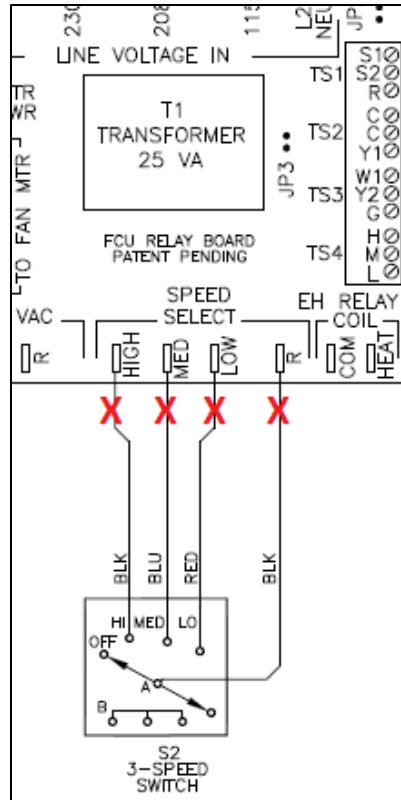

Figure 9 – Removing speed select jumper on unit with unit mounted 3-speed switch

6. Remove electric heat wires (see Figure 10)

- a. If present, remove wire from COM (color may vary) on “EH RELAY COIL” portion of FCRB.
- b. If present remove wire from HEAT (color may vary) on “EH RELAY COIL” portion of FCRB.

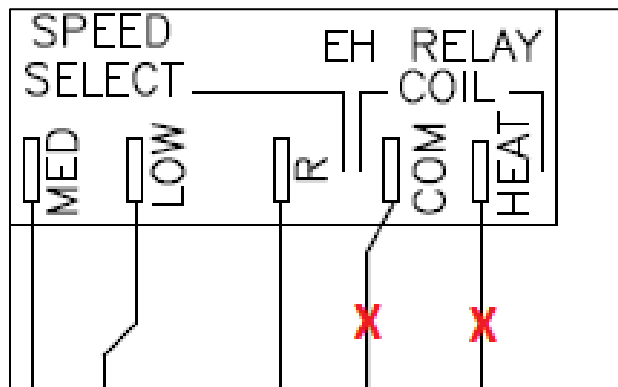

Figure 10 – Removing electric heat wires

7. Remove screw terminal wires (see Figure 11)

NOTE: Label each wire with the same name of the screw terminal it was removed from (i.e. S1, S2, R, etc.)

- a. Take note of the location of each of the wires connected to the screw terminals (for devices such as valves, thermostat, float switch, etc); these locations will be required in Step 12.
- b. Remove any wires connected to the screw terminal portion of the FCRB using a 1/8" flat blade screwdriver.

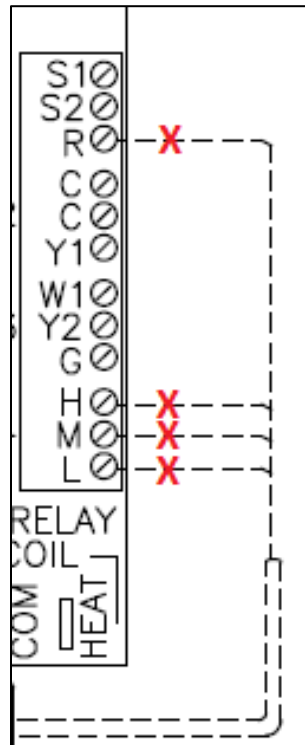

Figure 11 – Removing screw terminal wires (example)

8. Remove FCRB

- a. Verify that all wired connections have been removed from the FCRB.
- b. Remove the FCRB by removing all mounting screws that are present with a 1/4" nut driver.

9. Install FRBii

- a. Position the FRBii over the same surface and location that the FCRB was previously mounted in.
- b. Align the two “top” mounting holes on the FRBii (see Figure 12) to the location of the two “top” holes from where the FCRB was mounted (see Figure 13).
 - i. NOTE: The screw terminal portion of the FRBii should be in the same location where the screw terminal portion of the FCRB was previously.
- c. Install the FRBii using the six #8 x 3/4” hex washer self-tapping screws provided in the retrofit kit; one per each mounting hole (4 on the corners and 1 on each side of the transformer).



Figure 12 – FRBii mounting holes to align

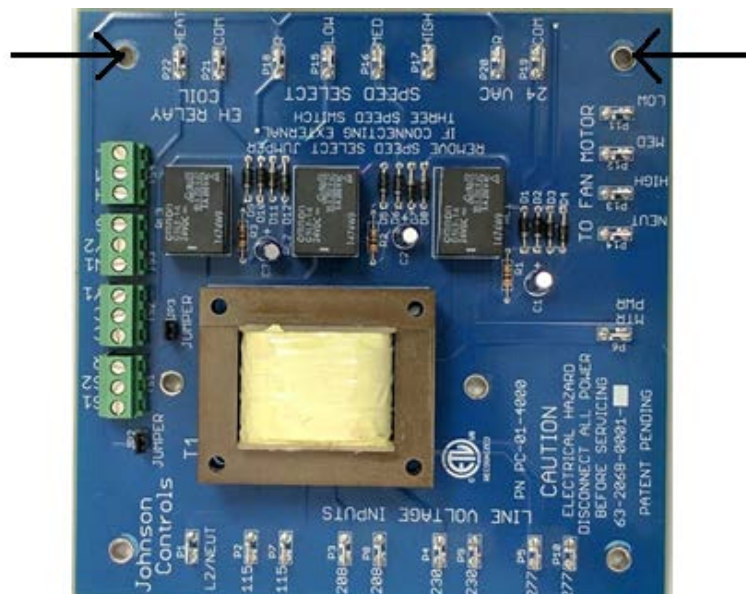

Figure 13 – FCRB mounting holes used for FRBii

10. Connect incoming power to FRBii (see Figure 14)**NOTE: Proceed to appropriate section below based on input voltage**

- a. Take WHITE/RED wire removed in Step 3 and install on male quick-connect/WHITE wire on WH3.
- b. Take BLACK wire removed in Step 3 and install on male quick connect/BLACK wire on WH3. The wire's location will depend on the unit's voltage:
 - i. 115V – P2
 - ii. 208V – P3
 - iii. 230V – P4
 - iv. 277V – P5
 - v. 220V/50Hz – P4

**Figure 14 – WH2 on J3 of FRBii**

11. Connect motor wires to FRBii (see Figures 15 and 16 – actual wire colors will vary based on motor type)

NOTE: Proceed to appropriate section below based on motor type

a. PSC Motors

- i. Take WHITE wire removed in Step 4 and install on male quick-connect/WHITE wire on WH5.
- ii. Take BLACK wire removed in Step 4 and install on male quick-connect/BLACK wire on WH5.
- iii. Take BLUE wire removed in Step 4 and install on male quick-connect/BLUE wire on WH5.
- iv. Take RED wire removed in Step 4 and install on male quick-connect/RED wire on WH5.

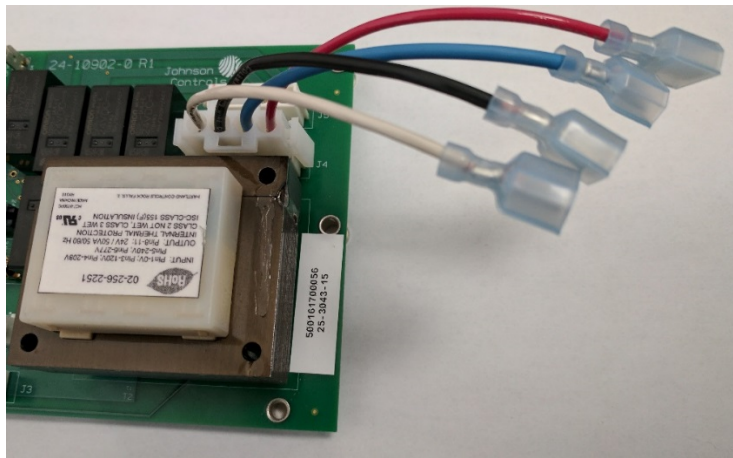

Figure 15 – WH5 on J4 of FRBii

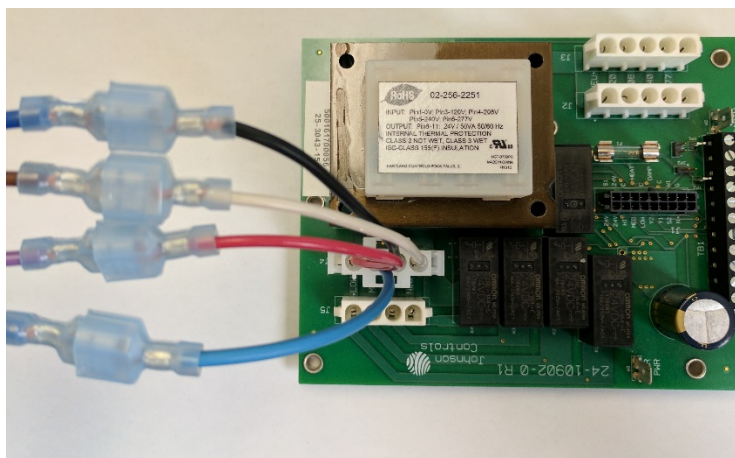

Figure 16 – WH5 connected to motor

b. EC Motors

- i. Take BLUE wire removed in Step 4 and install on male quick-connect/BLUE wire on WH5.
- ii. Take YELLOW wire removed in Step 4 and install on male quick-connect/YELLOW wire on WH5.
- iii. Take ORANGE wire removed in Step 4 and install on male quick-connect/ORANGE wire on WH5.
- iv. Take PURPLE wire removed in Step 4 and install on male quick-connect/PURPLE wire on WH5.
- v. Take BLACK wire removed from R on “24 VAC” portion of FCRB in Step 4 and install on male-quick/BROWN wire on WH2 (see Figure 20).
- vi. Take BLACK wire removed from “LINE VOLTAGE IN” portion of FCRB in Step 4 and install on male quick-connect/BLACK wire on WH3 (see Figure 18).
 1. **(DUAL MOTORS ONLY)** Cut off male quick-connect on BLACK wire on WH#. Locate the two BLACK wires removed from “LINE VOLTAGE IN” portion of FCRB in Step 4. Install all three wires into the 3-position lever nut (see Figures 17 and 18).
- vii. Take WHITE wire removed from COM on “24 VAC” portion of FCRB in Step 4 and install on male-quick/WHITE wire on WH2.
- viii. Take WHITE wire removed from NEUT on “TO FAN MTR” portion of FCRB in Step 4 and install on male quick-connect/WHITE wire on WH3.
 1. **(DUAL MOTORS ONLY)** Cut off male quick-connect on WHITE wire on WH3. Locate the two WHITE wires removed from “TO FAN MTR” portion of FCRB in Step 3. Install all three wires into the 3-position lever nut (see Figures 18 and 19).

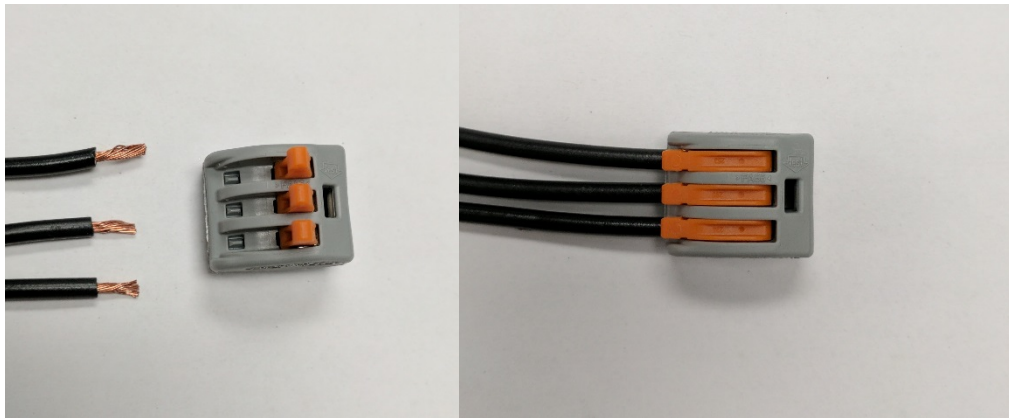

Figure 17 (left) and Figure 18 (right) – Before and after installing line voltage motor connection in 3-position lever nut for dual motors



Figure 19 – WH2 on J2 of FRBii

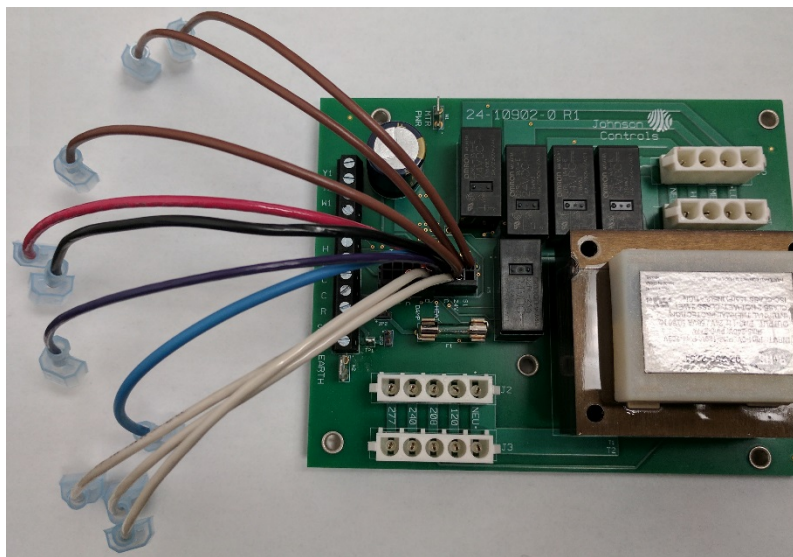

Figure 20 – WH1 on J1 of FRBii

c. EC 3SPD Motors

- i. Take RED/GRAY wire removed in Step 4 and install on male quick-connect/RED wire on WH5.
- ii. Take YELLOW/ORANGE wire removed in Step 4 and install on male quick-connect/YELLOW wire on WH5.
- iii. Take PURPLE wire removed in Step 4 and install on male quick-connect/WHITE wire on WH2 (see Figure 20).
- iv. Take jumper wire that was removed and retained in Step 4. Install one end on male quick-connect/BROWN wire on WH2. Install the other end on MTR PWR male pin on FRBii.
- v. Take WHITE wire removed in Step 4 and install on male quick-connect/WHITE wire on WH3.
 1. **(DUAL MOTORS ONLY)** Cut off male quick-connect on WHITE wire on WH3. Locate the two WHITE wires removed from “TO FAN MTR” portion of FCRB in Step 4. Install all three wires into the 3-position lever nut (see Figures 17 and 18).

- vi. Take BLACK/BLUE wire removed from HIGH on “TO FAN MTR” portion of FCRB in Step 4 and install on male quick-connect/BLACK wire on WH5.
- vii. Take BLACK wire removed from the “LINE VOLTAGE IN” portion of FCRB in Step 4 and install on male quick-connect/BLACK wire on WH3 (see Figure 19).
 - 1. **(DUAL MOTORS ONLY)** Cut off male quick-connect on BLACK wire on WH3. Locate the two BLACK wires removed from “LINE VOLTAGE IN” portion of FCRB in Step 4. Install all three wires into the 3-position lever nut (see Figures 17 and 18).

12. Connect Control Wires to FRBii

NOTE: The following section will cover the remaining connection from the “24VAC/SPEED SELECT/EH RELAY COIL” side of the FCRB.

- a. If unit has electric heat and Step 6 was performed:
 - i. Take wire removed from COM on “EH RELAY COIL” portion of FCRB (color may vary) and install on male quick-connect/WHITE wire on WH2.
 - ii. Take wire removed from HEAT on “EH RELAY COIL” portion of FCRB (color may vary) and install on male quick-connect/PUR wire on WH2.
- b. If unit has no 3SPD switch:
 - i. Take BROWN jumper wire removed in Step 5a. Install one end on male quick-connect/BLACK wire on WH2.
 - 1. **NOTE: BLACK** wire on WH2 is for HIGH speed. Connect to BLUE if MED speed is desire. Connect to RED if LOW speed is desired.
 - ii. Install other end on male quick-connect/BROWN wire on WH2.
- c. If unit has a Unit Mounted 3SPD Switch:
 - i. Take BLACK wire removed in Step 5 and install on male quick-connect/BLACK wire on WH2.
 - ii. Take BLUE wire removed in Step 5 and install on male quick-connect/BLUE wire on WH2.
 - iii. Take RED wire removed in Step 5 and install on male quick-connect/RED wire on WH2.
 - iv. Take BLACK wire removed in Step 5 and install on male quick-connect/BROWN wire on WH2.

13. Connect screw terminal wires to FRBii (See Figure 21)

- a. Take any wires removed from the FCRB in Step 7 and install them into the screw terminals of the FRBii. The FCRB and FRBii screw terminals have identical names and wires removed from the FCRB should go to the corresponding terminal on the FRBii (NOTE: order of screw terminals is different; see Figure 21).

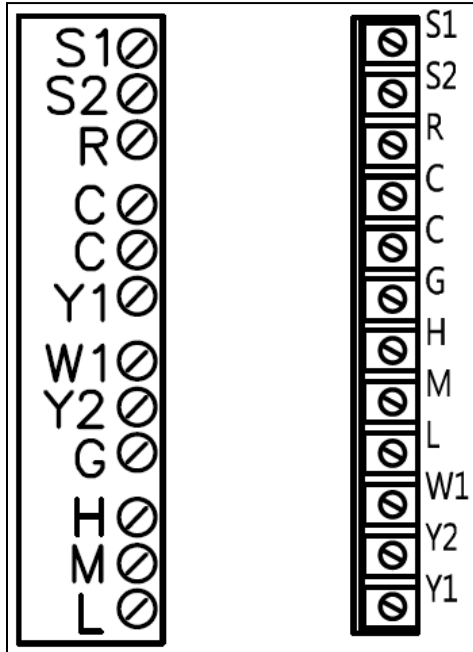

Figure 21 – FCRB screw terminals (left) vs FRBii screw terminals (right)

14. Connect ground to FRBii (see Figure 22)

- a. Install the female quick-connect end of wiring harness WH1 to the EARTH male terminal on the FRBii (see Figure 22).
- b. The stripped end should be grounded to the inside of the control enclosure.

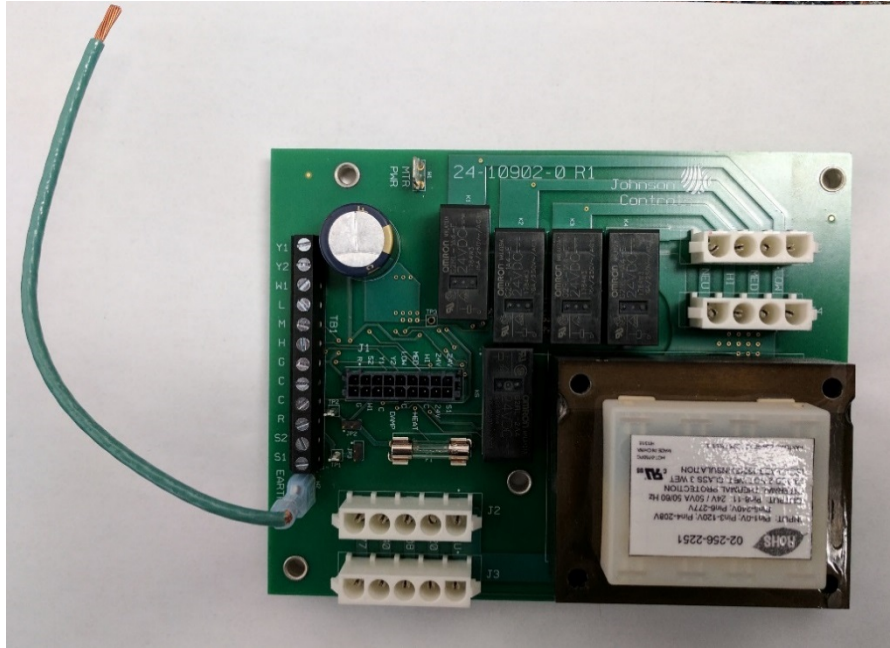

Figure 22 – Install WH1 on EARTH of FRBii

15. Verification

- a. Verify all wiring connections per the wiring diagram stored in the unit and the figures in this instruction.
 - i. Ensure that no wires other than the ones specified in Steps 3-7 were disconnected.
 - ii. Ensure that the new wires have been connected as specified in Steps 10-14.
- b. Verify operation.
- c. Leave the revised wiring diagram (WD1) with the unit in the electrical enclosure.
- d. Leave the existing wiring diagram with the unit in the electrical enclosure.

END